

Agilent TPS-flexy

Do-It-Yourself Vacuum!

Create your integrated turbo pumping system with TwisTorr 74 FS and 305 FS Turbo Pump, Onboard or Remote Controller, IDP-3 and IDP-7 Dry Scroll Pumps or MD-1 Diaphragm Pump. Order the TPS-flexy package, follow easy assembling instructions plus video tutorial and get your system up and running in a few minutes!

Ordering Information

TPS-flexy description					Part Number
Turbo Pump	Flange	Primary Pump	Voltage	Controller	
TwisTorr 74FS	KF 40	IDP3	240V	Onboard C/U	X1699-64077
TwisTorr 74FS	KF 40	IDP3	240V	Remote C/U	X1699-64078
TwisTorr 74FS	KF 40	IDP3	120V	Onboard C/U	X1699-64081
TwisTorr 74FS	KF 40	IDP3	120V	Remote C/U	X1699-64082
TwisTorr 74FS	CFF 2.75"	IDP3	240V	Remote C/U	X1699-64101
TwisTorr 74FS	ISO 63	IDP3	120V	Onboard C/U	X1699-64080
TwisTorr 74FS	ISO 63	IDP3	240V	Remote C/U	X1699-64094
TwisTorr 74FS	ISO 63	IDP3	120V	Remote C/U	X1699-64096
TwisTorr 74FS	ISO 63	IDP3	240V	Onboard C/U	X1699-64100
TwisTorr 74FS	CFF 4.5"	IDP3	240V	Onboard C/U	X1699-64079
TwisTorr 74FS	CFF 4.5"	IDP3	120V	Onboard C/U	X1699-64083
TwisTorr 74FS	CFF 4.5"	IDP3	240V	Remote C/U	X1699-64095
TwisTorr 74FS	CFF 4.5"	IDP3	120V	Remote C/U	X1699-64097
TwisTorr 74FS	KF 40	MD1	100-240V	Onboard C/U	X1699-64085
TwisTorr 74FS	KF 40	MD1	100-240V	Remote C/U	X1699-64086
TwisTorr 74FS	CFF 2.75"	MD1	100-240V	Remote C/U	X1699-64102
TwisTorr 74FS	ISO 63	MD1	100-240V	Onboard C/U	X1699-64084
TwisTorr 74FS	ISO 63	MD1	100-240V	Remote C/U	X1699-64098
TwisTorr 74FS	CFF 4.5"	MD1	100-240V	Onboard C/U	X1699-64087
TwisTorr 74FS	CFF 4.5"	MD1	100-240V	Remote C/U	X1699-64099
TwisTorr 74FS	KF 40	IDP7	100-240V	Remote C/U	X1699-64104
TwisTorr 74FS	KF 40	IDP7	100-240V	Onboard C/U	X1699-64107
TwisTorr 74FS	CFF 2.75"	IDP7	100-240V	Onboard C/U	X1699-64105
TwisTorr 74FS	CFF 2.75"	IDP7	100-240V	Remote C/U	X1699-64106
TwisTorr 74FS	ISO 63	IDP7	100-240V	Remote C/U	X1699-64116
TwisTorr 74FS	CFF 4.5"	IDP7	100-240V	Remote C/U	X1699-64103
TwisTorr 305FS	ISO 100	IDP3	240V	Onboard C/U	X1699-64121
TwisTorr 305FS	ISO 100	IDP3	240V	Remote C/U	X1699-64122
TwisTorr 305FS	ISO 100	IDP3	120V	Remote C/U	X1699-64127
TwisTorr 305FS	CFF 6"	IDP3	240V	Onboard C/U	X1699-64123
TwisTorr 305FS	CFF 6"	IDP3	240V	Remote C/U	X1699-64125
TwisTorr 305FS	CFF 6"	IDP3	120V	Remote C/U	X1699-64131
TwisTorr 305FS	ISO 100	MD1	100-240V	Remote C/U	X1699-64129
TwisTorr 305FS	ISO 100	MD1	100-240V	Onboard C/U	X1699-64130
TwisTorr 305FS	ISO 100	IDP7	100-240V	Onboard C/U	X1699-64118
TwisTorr 305FS	ISO 100	IDP7	100-240V	Remote C/U	X1699-64119
TwisTorr 305FS	CFF 6"	IDP7	100-240V	Onboard C/U	X1699-64120
TwisTorr 305FS	CFF 6"	IDP7	100-240V	Remote C/U	X1699-64124
TwisTorr 305FS	CFF 6"	IDP10	100-240V	Remote C/U	X1699-64126*

www.agilent.com/chem/tps-flexy

United States
 Agilent Technologies
 Toll free: +1 800 882 7426
vpl-customer@agilent.com

Europe and other countries
 Agilent Technologies Italia SpA
 Toll free: 00 800 234 234 00
vpl-customer@agilent.com

This information is subject to change without notice.

© Agilent Technologies, Inc. 2020
 Published in the USA, February 14th, 2020
 5994-0450EN

* Special version with IDP-10 Dry Scroll Pump, please ask Agilent for details

TPS-flexy with TwisTorr 74 FS and MD-1

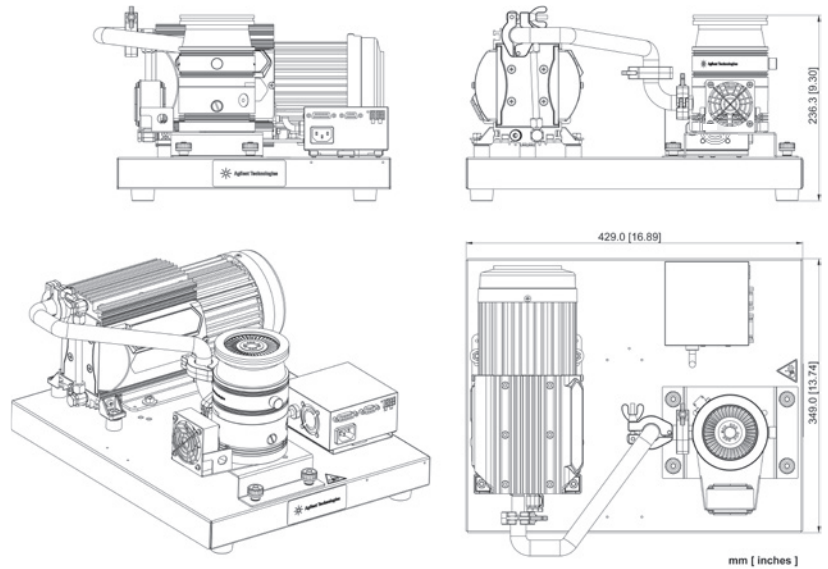

Pumping Speed vs Inlet Pressure

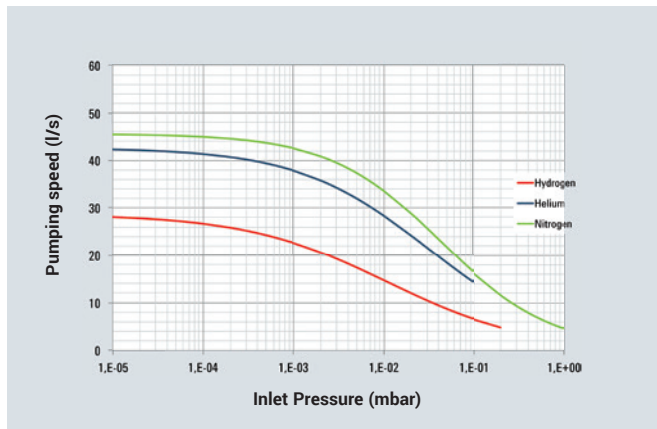

Pressure vs Time (with a pump down vol. of 15 l)

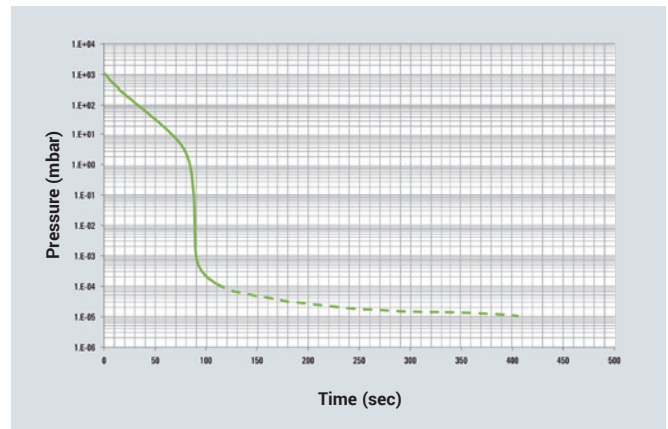

Technical Specifications

		KF 40	ISO 63	CFF 4.5 in.
Pumping Speed (l/s) (with inlet screen)	N ₂	33	45	45
	He	25	41	41
	H ₂	20	27	27
Base pressure*		2 x 10 ⁻⁷ mbar	2 x 10 ⁻⁷ mbar	5 x 10 ⁻⁸ mbar
Bakeout temperature		80 °C at inlet	80 °C at inlet	120 °C at inlet
Pumpdown time (1 liter volume)		60 sec. to 17 mbar; 114 sec. to 1 x 10 ⁻⁴ mbar; 140 sec. to 5 x 10 ⁻⁵ mbar		
Turbo pump rotational speed		70000 RPM		
Start-up time		122 sec.		
Operating ambient temperature		5 °C to 35 °C / 32 °F to 122 °F		
Input Voltage and Frequency		90V to 240V AC; 50 Hz / 60 Hz		
Serial communications		RS-232 cable, 9-pin D-type male, 9-pin D-type female, T-Plus Navigator Software		

* According to standard DIN 28 428

TPS-flexy with TwisTorr 74 FS and IDP-3

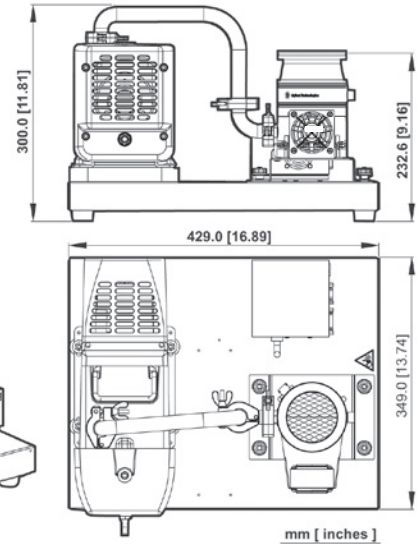
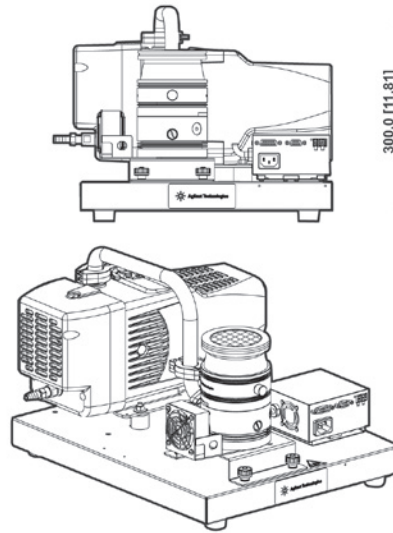

Pumping Speed vs Inlet Pressure

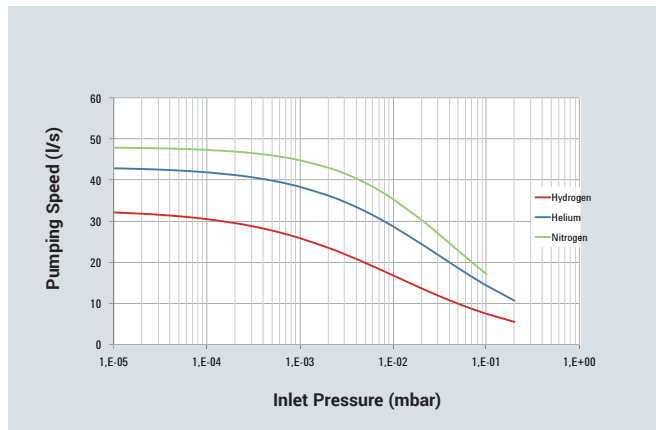

Pressure vs Time (with a pump down vol. of 15 l)

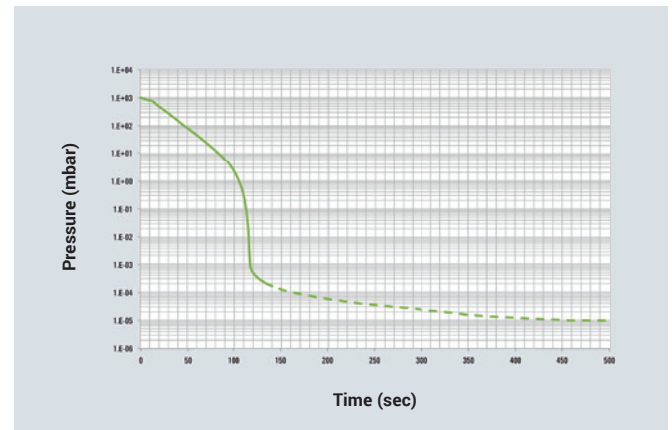

Technical Specifications

		KF 40	ISO 63	CFF 4.5 in.
Pumping Speed (l/s) (with inlet screen)	N ₂	37 l/s	48 l/s	48 l/s
	He	29 l/s	44 l/s	44 l/s
	H ₂	23 l/s	32 l/s	32 l/s
Base pressure*		1 x 10 ⁻⁸ mbar	1 x 10 ⁻⁸ mbar	1 x 10 ⁻⁹ mbar
Bakeout temperature		80 °C at inlet	80 °C at inlet	120 °C at inlet
Pumpdown time (15 liter volume)	46 sec. (100 mbar); 104 sec. (1 mbar); 160 sec. (1 x 10 ⁻⁴ mbar); 210 sec. (5 x 10 ⁻⁵ mbar); 400 sec. (1.3 x 10 ⁻⁵ mbar)			
Turbo pump rotational speed	70000 RPM			
Start-up time	144 sec.			
Operating ambient temperature	5 °C to 35 °C / 32 °F to 122 °F			
Input Voltage and Frequency	115 Vac 60 Hz or 220-240 Vac 50/60 Hz			
Communications	RS232 - Analogical I/O			

* According to standard DIN 28 428

TPS-flexy with TwisTorr 305 FS and IDP-7

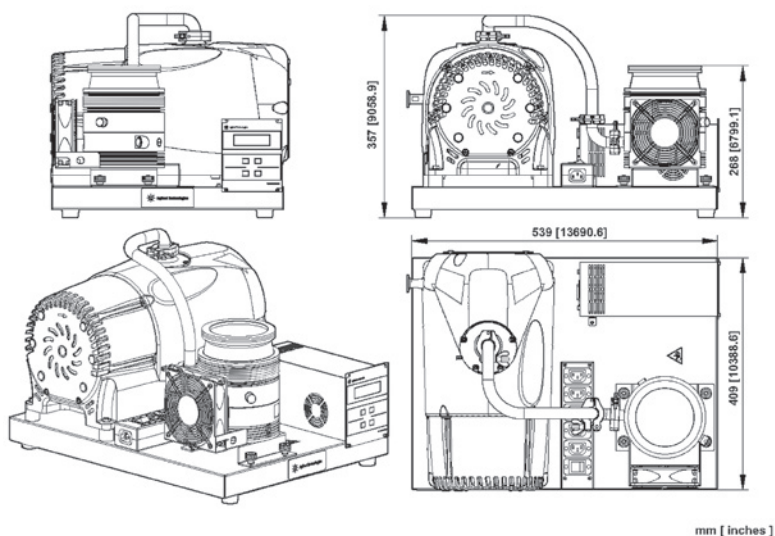

Pumping Speed

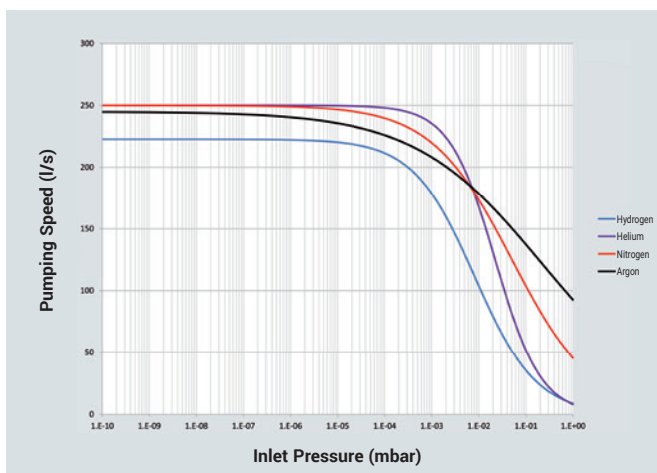

Pressure vs Time (with a pump down vol. of 15 l)

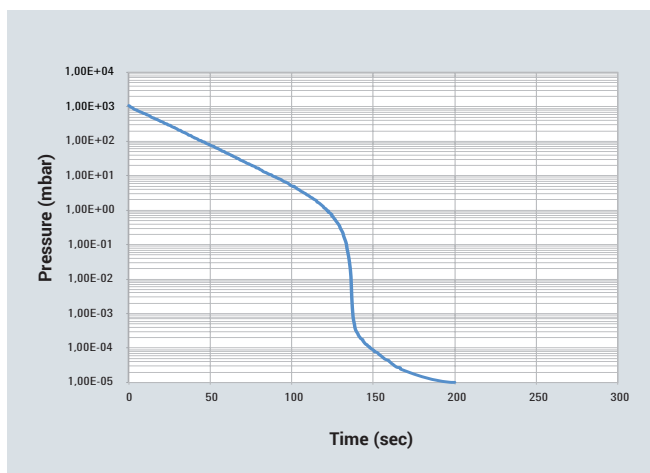

Technical Specifications

Pumping speed	ISO 100 / CFF 6 "
N ₂	250 l/s
He	255 l/s
H ₂	220 l/s
Ar	250 l/s
Rotational speed	60000 rpm (1010 Hz driving frequency)
Start-up time	< 3 minutes
Operating ambient temperature	+5 °C to +35 °C
Relative humidity of air	0 - 90 % (not condensing)
Bakeout temperature	80 °C at inlet flange max (ISO flange)